

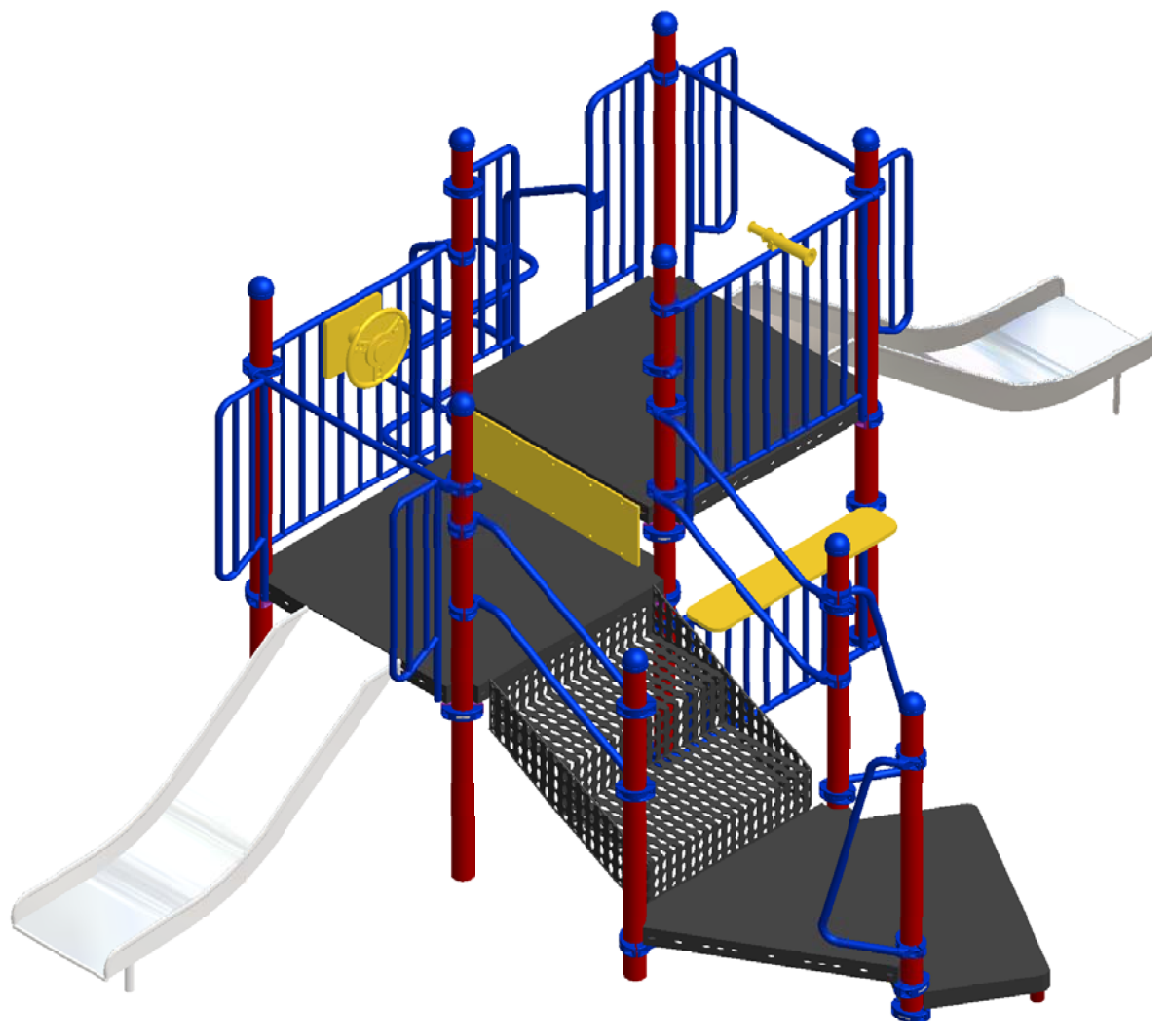



23 ch. Boom Lane, Unit/Unité E  
 Industrial Park/Parc industriel  
 Atholville, New/Nouveau-Brunswick  
 Canada, E3N 4E8  
 Tel/tél. : 1-888-212-1411/Fax/télec. : 1-888-789-0987  
 go@kangaroo.com / www.kangaroo.com



<b>Kroll-ss118</b>	Min. Protective Surface Required / Surface de protection min. requise : 9.6 m (31'-5") x 7.9 m (25'-9")	Equipment Dimensions / Dimensions de l'équipement : 5.9 m (19'-5") x 4.2 m (13'-9")	Approval date: 2011-01-06 Rev: 00 Initial: TLG
CAN/CSA-Z614-xx xx: Last Edition Published/ Dernière édition publiée	Recommended Ages / Âges recommandés : 18 months to 5 years old / 18 mois à 5 ans	Capacity / Peut accueillir : up to 20 children / Jusqu'à 20 enfants	



23 ch. Boom Lane, Unit/Unité E  
 Industrial Park/Parc industriel  
 Atholville, New/Nouveau-Brunswick  
 Canada, E3N 4E8  
 Tel/tél. : 1-888-212-1411/Fax/télé. : 1-888-789-0987  
 go@kangoroo.com / www.kangoroo.com

Legend / Légende

#	Description
1	Loop Climber 48" / Échelle à boucles 48"
2	Counter Panel / Panneau comptoir
3	Telescope Panel / Panneau télescope
4	Riser 12" / Contremarche 12"
5	Car Panel / Panneau auto
6	Transfer Station / Marches de transfert
7	Stainless Steel Slide 36" / Glissoire en acier inox. 36"
8	Stainless Steel Slide 48" / Glissoire en acier inox. 48"

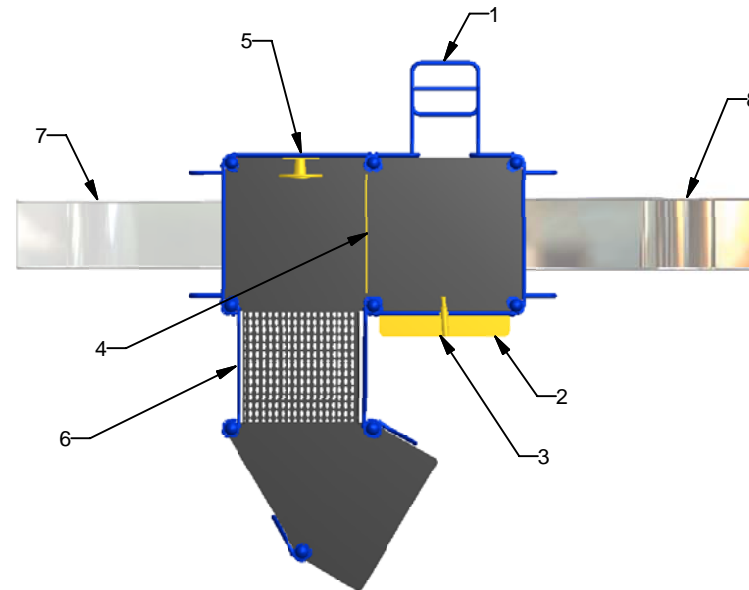
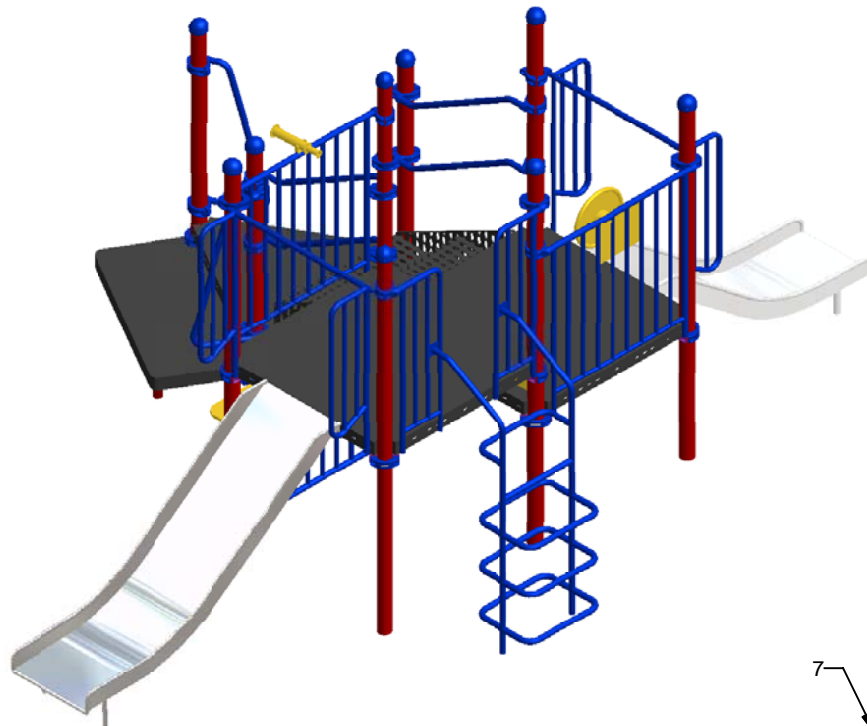

<b>Kroll-ss118</b>	Min. Protective Surface Required / Surface de protection min. requise : 9.6 m (31'-5") x 7.9 m (25'-9")	Equipment Dimensions / Dimensions de l'équipement : 5.9 m (19'-5") x 4.2 m (13'-9")	Approval date: 2011-01-06 Rev: 00 Initial: TLG
CAN/CSA-Z614-xx xx: Last Edition Published/ Dernière édition publiée	Recommended Ages / Âges recommandés : 18 months to 5 years old / 18 mois à 5 ans	Capacity / Peut accueillir : up to 20 children / Jusqu'à 20 enfants	

PLATFORM HEIGHTS  
HAUTEURS DE PLATEFORME

6" = 152MM	60" = 1524MM
12" = 305MM	72" = 1829MM
24" = 609MM	84" = 2134MM
36" = 915MM	96" = 2438MM
48" = 1219MM	

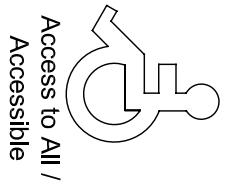
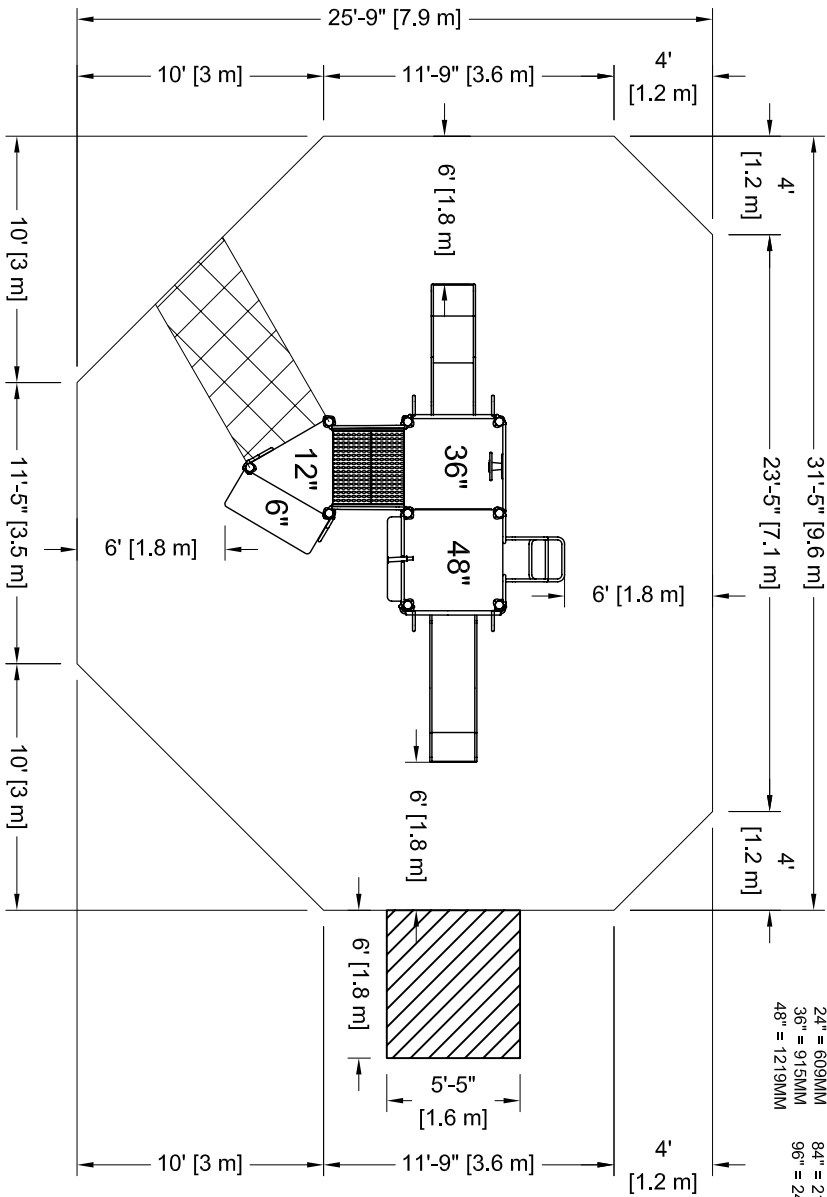

Access to All / Accessible

Aire praticable en fauteuil roulant



Wheel chair accessible surface:

- Aire : 2,76 m ca ( 29,75 pi ca.)

-Surface: 2,76 sq.m.( 29,75 sq.ft.)

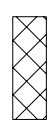

**Kroll-ss118**

Min. Protective Surfacing Zone Required / Zone de protection min. requise : 9,6 m (31'-5") x 7,9 m (25'-9")

Equipment Dimensions / Dimensions de l'équipement : 5,9 m (19'-5") x 4,2 m (13'-9")

CAN/CSA-Z614-xx  
xx: Last Edition Published / Dernière édition publiée

Recommended Ages / Âges recommandés : 18 months to 5 years old / 18 mois à 5 ans

Capacity / Peut accueillir : up to 20 children / Jusqu'à 20 enfants

**Légende :**

- Zone de protection minimum
- Aire de circulation libre
- Autre

Zone de protection minimum requise:  
- Aire : 64,45 m.ca. (693,81 pi. ca.)

**SI INSTALLATION DANS LE BÉTON**

Sonotube de 12" Ø x 12':  
- Quantité : 2  
- Béton :  
- 1,1 vge cu.

**Attention :**

**ZONE DE PROTECTION:**  
Chaque équipement doit avoir une zone de protection constituée d'une surface sans obstacle qui se prolonge dans toutes les directions à partir du périmètre de l'équipement. Cette zone doit contenir un revêtement de surface (gravier, sable, etc...) avec une capacité d'amortissement selon les normes CSA-Z614.  
Sauf avis contraire.  
Voir dessin pour les dimensions de la zone.

**AIRE DE CIRCULATION LIBRE:**  
Aire dégagée d'obstacle qui se prolonge sur au moins 1,8m (70,87") au delà de la zone de protection. Voir dessin pour les détails.

**Légende:**

- Minimum Protective Surfacing Zone
- No-Encroachment Zone
- Other

Minimum Protective Surfacing Zone required:  
- Surface: 64.45 sq. m (693.81 sq. ft.)

**IF INSTALLED IN CONCRETE**

Sonotube of 12" Ø x 12':  
- Quantity: 2  
- Concrete:  
- 1.1 cu. yd.

**Warning:**

**PROTECTIVE SURFACING ZONE:** Each equipment shall have a protective surfacing zone that consist of obstacle-free surfacing surrounding the equipment. This zone shall contain shock absorbing material (see gravel, sand, etc...) that comply with CSA-Z614. Unless noted otherwise. See drawing for dimensions of zone.

**NO-ENCROACHMENT ZONE:** Obstacle-free zone extending at least 1,8m (70,87") beyond the protective surfacing zone. See drawing for details.

Approval date: 06-01-2011  
Rev: 00  
Initial: TLG

